

# PIONEER TURNTABLES

PL-L800/PL-8/PL-7/PL-5/PL-4/PL-2







FURMAN



# PIONEER TURNTABLES

## Masterpieces of Audio Art

In appearance, engineering and, most of all, performance, each and every model in the new Pioneer turntable lineup is an individual expression of perfection.

So advanced is our engineering that all Pioneer turntables, regardless of price, have several provably superior features in common.

Take, for instance, the tone arm. Each is straight and constructed using Polymer Graphite\* for lower mass and improved rigidity. And our drive motors; every model except the PL-2 now uses the unique

Pioneer-developed Stable Hanging Rotor\* motor.

And the top-of-the-line PL-L800, equipped with a highly accurate and convenient tangential-tracking system, represents the pinnacle of our engineering expertise.

All of our turntables share several other important features that contribute to uncommonly convenient operation and clean lines. All essential operational controls are touch sensitive and located on the front edge for direct access even with the dust cover

closed. Indicators are highly readable and so laid out as to allow instant status identification. And naturally, each Pioneer turntable is a perfect match with other contemporary Pioneer equipment both in appearance and performance.

We invite you to compare our turntable masterpieces with any others on the market. We're confident that you'll choose Pioneer. (\*Polymer Graphite and Stable Hanging Rotor are trademarks of Pioneer.)





## Accurate Platter Motor: Stable Hanging Rotor and Coreless Design

A motor is the heart of a turntable, responsible for accurately rotating the record-bearing platter. At Pioneer we felt that even the most advanced current motor design wasn't good enough. Therefore, we took a close look at the basic design of the turntable motor. What we came up with is a radical departure — the Stable Hanging Rotor design coupled with a cog-free coreless DC motor. This no-compromise precision motor has greatly contributed to an overall improvement in the quality of reproduction.

### A: The Stable Hanging Rotor Design

If you look inside a conventional motor, you'll notice that its fulcrum is at the very base of the motor. Therefore it's impossible for the center of gravity of the platter-motor system to coincide with the fulcrum, as it should, to achieve perfect rotational equilibrium. As a result, the pivot (motor shaft) wobbles microscopically on the fulcrum. The wobbles are transmitted to the platter in the form of wow and flutter — the enemies of accurate reproduction.

Pioneer's Stable Hanging Rotor design motor has eliminated this source of wow and flutter entirely. The fulcrum lies immediately below the platter on a truncated spindle (see cross-section) and around a raised, fixed motorshaft. In other words, the fulcrum exactly coincides with the center of gravity of the platter.

### B: Pioneer's Coreless Motor

Another factor contributing to improved wow and flutter is the coreless design of our motor. Standard designs employ any number of iron cores and slots to provide sufficient torque. But these cores and slots are the source of torque ripples called "cogging." Cogging is extremely harmful to accurate musical reproduction.

As its name implies, our coreless DC motor does not use cores or slots. Instead, the driving coils have "air cores" and are mounted flat on the circuit board. Since there are no cores and slots, torque is smooth and ripple-free.

The PL-L800 down through the PL-4 successfully combine two brilliant techniques — the Stable Hanging Rotor and the coreless motor; this motor is one of the most accurate available now and probably for some time to come, achieving exceptionally low wow and flutter of 0.025% (WRMS).

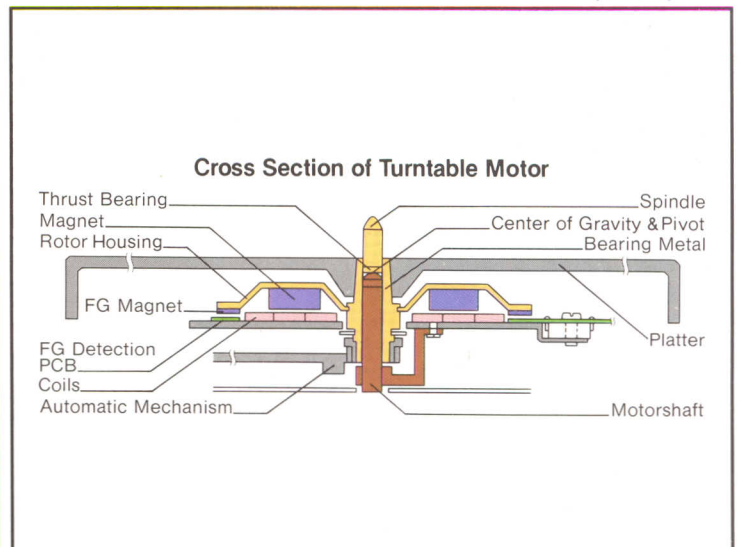
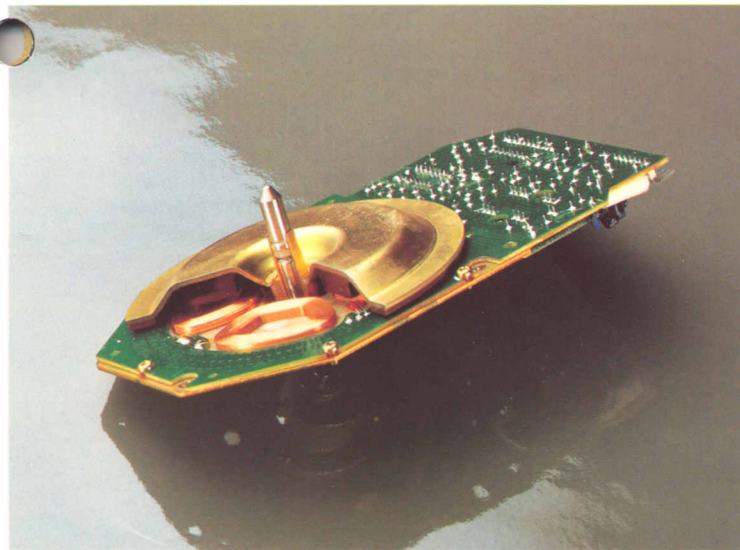

## Accurate Speed Control System: Quartz-PLL Servo with Periphery Integration

In the motor of the top three models we've employed the most accurate and responsive servo control system available to compensate for speed deviation: a Quartz-PLL servo system. It compares a reference signal from a quartz crystal oscillator for speed difference with a speed-proportional signal from a speed-detector system in the motor. Any difference in phase, which represents speed error, is compensated for

instantly, locking the platter speed with the quartz signal in the PLL (Phase-Locked Loop) circuitry.

To obtain the speed-proportional signal from the motor, we've employed another elaborate device — the Periphery Integration system. This system utilizes magnetic poles printed on the underside of the rotor magnet housing and the coils printed on the circuit board to generate four hundred electronic

pulses every second that are compared with the quartz reference. Its effectiveness lies in its uncanny responsiveness to changes in dynamic loading conditions due to warps, eccentricities, etc. As a final touch, switching of magnetic poles is accomplished by semiconductor Hall elements, not brushes. Common mechanical noise is totally inaudible.



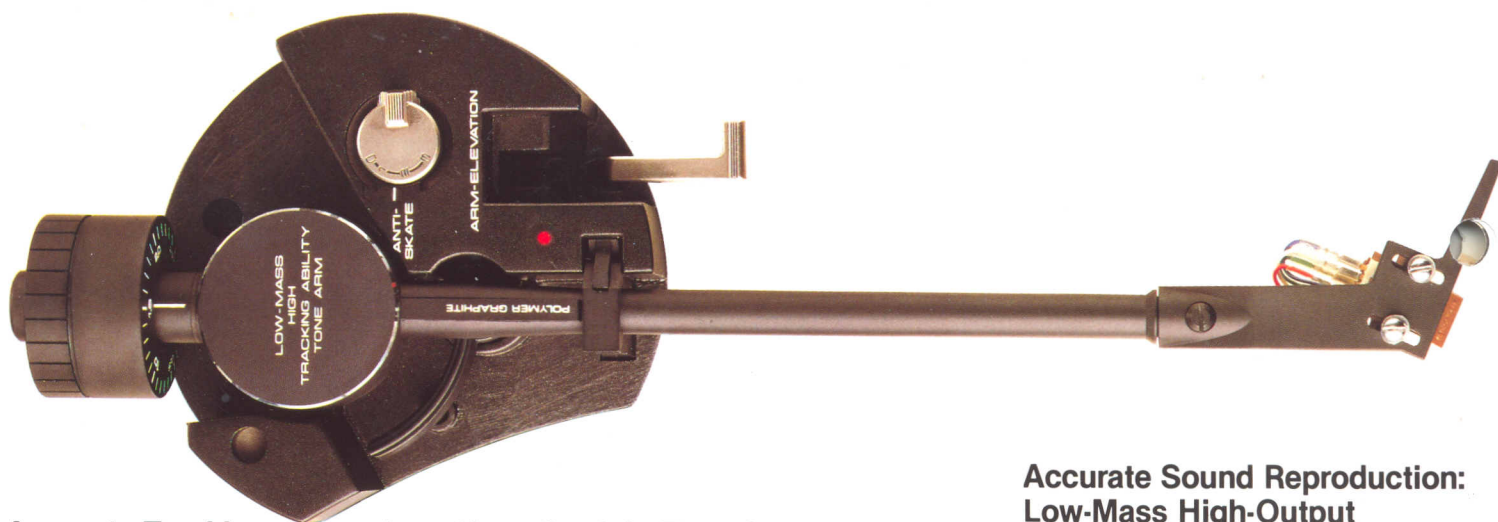

## Accurate Tracking: Low-Mass Straight Tone Arm

To properly play warped records or records with a wide dynamic range, the entire pick-up system including tone arm and cartridge must be provided with impeccable tracking ability. Pioneer has designed such a system. It is capable of tracking virtually any record. Intermodulation distortion is reduced and reproduction is clarity itself. Here's how we did it:

### A: Polymer Graphite Tone Arm

Polymer Graphite (or "PG" for short) is a new material that Pioneer engineers discovered in their quest for a better tone arm material. PG displays high specific modulus of elasticity and high internal loss — in other words, it's rigid and firm while having ultra-low mass.

High mass arms have an inherent inability to trace warped or eccentric records because of their high moment of inertia. The stylus may seriously mistrack the groove or degrade reproduction quality in some other subtle manner.

A low-mass arm with a properly designed cartridge can track the high-modulation grooves as found in wide-dynamic-range audiophile recordings with high-quality, high-compliance cartridges. The tone arms of our PL-Series turntables fit the bill perfectly.

Another tone arm design factor is arm resonance. While low frequency resonances can never be entirely prevented, ideally, the resonance should be around 10Hz — below audible frequencies but above the destructive warp frequencies. And only a low-mass tone arm, like the mechanically strong PG tone arm found on all models, offers ideal 10Hz resonance in combination with high-quality high-compliance cartridges. For additional strength, each PG tone arm is constructed with a coaxial aluminum tube.

### B: Straight Tube and Headshell

Unlike many conventional S- or J-shaped tone arms, ours are straight. The headshell is angled for minimum horizontal tracking error. The straight tone arm is less massive and stronger than conventional designs. The headshell is made of polymer compound to further reduce mass.

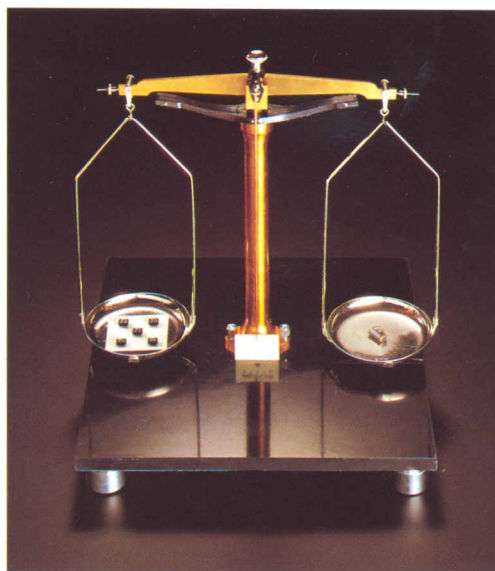
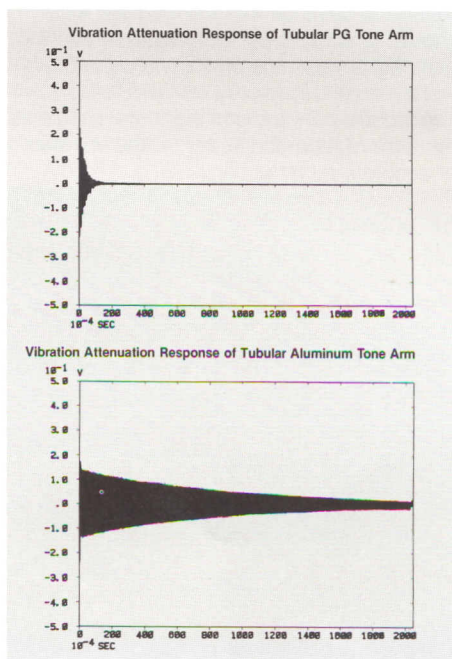

● The new Pioneer PC-4MC is exceptionally low in mass, thanks to the use of magnets with high energy products. Thus its entire magnetic structure is about 1/5 as heavy as that of conventional moving-coil cartridges. Linearity and efficiency are both improved.

## Accurate Sound Reproduction: Low-Mass High-Output Moving-Coil Cartridge

The PL-L800 comes with a moving-coil cartridge. This Pioneer-developed cartridge (pat. pend.) features three poles and two magnets per channel. The magnets are powerful samarium cobalt types (BHmax = 10,000 gauss), mounted symmetrically in the housing. This results in linear response over an exceptionally wide amplitude range. The frequency response is wide and flat, the separation wonderfully wide thanks to the independent generating systems for each channel. The output of this cartridge is unusually high for a moving-coil type. This means it can couple directly with a normal MM (Moving-Magnet) phono input of any amplifier; no pre-preamp (head amp) or step-up transformer is necessary.

The weight of this cartridge is only 3.1 grams — half as massive as typical moving-coil cartridges — in consonance with the low-mass design theory of the tone arm. Surprise! You don't need to return the cartridge to us to replace the stylus. Just pluck it off and insert a new one as you would with a popular moving-magnet type cartridge.

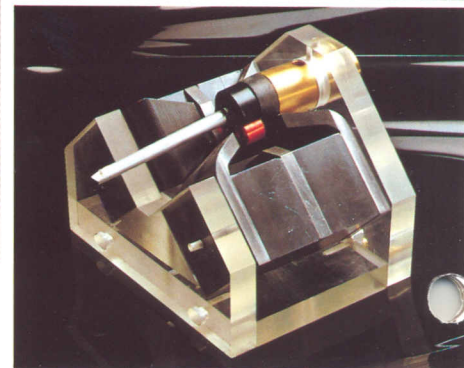
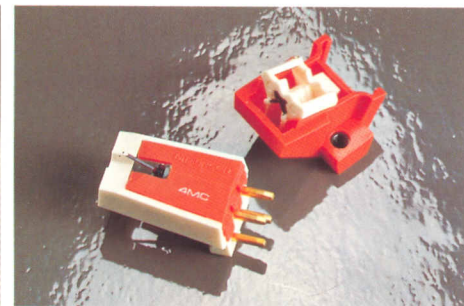



## Perfect Isolation: Coaxial Suspension System

Pioneer's elaborate Coaxial Suspension System completely isolates the tone arm, platter and motor from external shock. Slight jolts to the cabinet won't budge the tracking stylus and cause mistracking. Here's why:

The cabinet is supported on four spring-coupled insulators; inside the cabinet is an independent structure on which sit the tone arm, platter and motor — the parts of the turntable that must be protected against even the slightest vibration. This structure is suspended on springs. All vibration reaching the cabinet is thus absorbed *before* it can harm reproduction. That's why all Pioneer turntables boast high sonic clarity unaffected by external vibrations or acoustic feedback.

### Cross Section of Coaxial Suspension System (PL-L800)

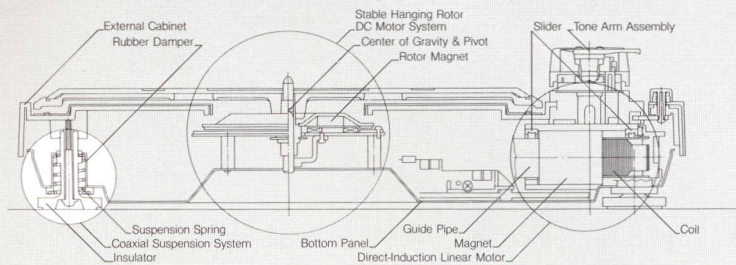

## Tangential Tracking

When a disc is cut on a master lathe, the cutting head moves across the virgin lacquer disc in a straight line from the edge to the center. A cutting stylus inscribes a groove on the surface of the disc. It's evident then that the most accurate way of recovering the information inscribed on the disc is with a stylus that tracks in a straight line — that is, one mounted on a tangential tracking arm.

A tone arm which tracks in a straight line, when properly designed, engineered and manufactured, will eliminate skating force and horizontal tracking error, along with the excessive record wear they cause.

We have successfully developed a tangential tracking arm *without* any inherent disadvantages. We achieved this with a gearless non-contact linear motor that provides vibration-free, smooth lateral movement through magnetic induction.

Compare ours with other nonmagnetically controlled tangential tracking arms, which depend on ordinary vibration-prone motors driving rollers, worm screws or pulleys. In performance terms, there's simply no comparison.

### ● Four Advantages — Plus a Pioneer Exclusive

Tangential tracking arms have four major advantages over pivoted types:

(1) Tracking angle error, for all practical purposes, is zero throughout the playing process. Due to the geometry of arm pivot and offsets angle, pivoted arms can only be designed with minimized tracking error angles on the order of perhaps two degrees of arc; a tangential arm, always tracking the record groove at an exactly perpendicular angle, has no tracking error angle and therefore causes no error-induced f.i.m.

(frequency intermodulation) distortion.

(2) There is no inward skating force, and no anti-skating system is required. (This advantage is also due to the ideal arm geometry and the absence of a fixed pivot point.)

(3) Lateral balance is ideal, because the arm's geometry allows mass to be distributed equally to left and right.

(4) Effective mass is low, because the arm can be made short and straight. (The important of low arm mass has already been discussed above.)

Pioneer's tangential tracking turntable has still another advantage: all forms of speed-reduction/force-transmission linkage have been eliminated from the tangential tracking arm. Basic performance specifications are thus safeguarded against additional noise and vibration, unlike in many other tangential tracking turntables.

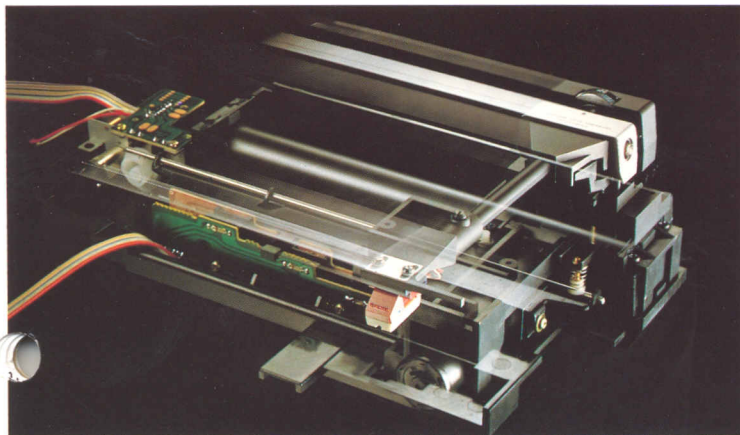

### Structure of Direct-Induction Linear Motor

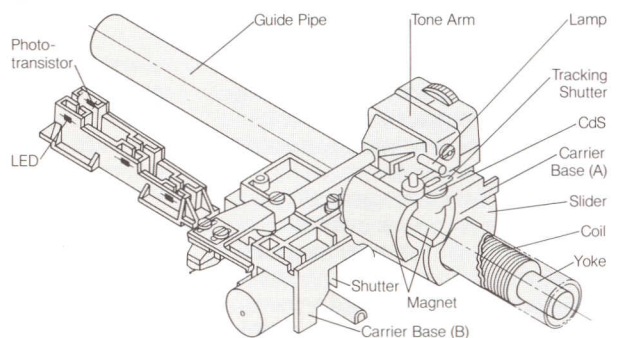



# PL-L800

**PG**  
POLYMER GRAPHITE



\*Metal-like resin cabinet.

## The Second-Generation Tangential Tracking Turntable

A TANGENTIAL TRACKING TURNtable is a radical departure from more conventional pivoted arm designs. When flawlessly engineered, this design approach can reduce horizontal tracking error to zero; crossmodulation, crosstalk and even stylus/record wear are kept to a minimum. Despite overwhelming advantages, however, tangential tracking turntables normally pay a penalty — a poor signal-to-noise ratio.

The Pioneer PL-L800 is significantly different from other tangential tracking designs. It uses a linear motor for horizontal movement of the tone arm to maintain the stylus ideally tangent to the record grooves. It has no vibration-susceptible rollers, worm screws or pulleys to degrade sound quality. Thus, the PL-L800 boasts an unusually high

signal-to-noise ratio of 78dB.

The short (6-1/2-inch or 162mm) low-mass straight tone arm is constructed of a Pioneer-developed material called PG or Polymer Graphite. Displaying low-mass, it tames resonance for better tracking. Being axisymmetrical, it achieves optimum lateral balance for higher mechanical strength. It's fitted with a lightweight carbon-blended polymer headshell. The shell mounts Pioneer's new PC-4MC moving coil cartridge but it's also capable of mounting just about any other cartridge on the market.

A no-contact opto-electronic arm deflection detect/compensate servo system at the base of the arm maintains the arm 90° tangent to the record groove (with a nominal error of up to 0.2°) at any point across the

record. A similarly elaborate opto-electronic system is employed for no-contact detection of end of record play. A second DC motor controls arm lift.

Naturally, all popular Pioneer exclusives, such as our Stable Hanging Rotor coreless DC motor, Quartz-PLL servo control and Coaxial Suspension, are included. The PL-L800 is a fully automatic turntable, controlled and supervised by a microprocessor (PD6005) for safe operation. All controls are up front and are light-touch sensitive.



# PL-8

**PG**<sup>TM</sup>  
POLYMER GRAPHITE



\*Metal-like resin cabinet.

## The Turntable That Beckons to be Listened To

IF YOU'RE OF THE OPINION THAT A turntable doesn't affect reproduction quality in a hi-fi system, Pioneer suggests that you *listen* to the PL-8. Just one listen will convince you that your records have never sounded better, cleaner, more definitive.

The PL-8, like all Pioneer turntables, has an arm of the low-mass straight PG (Polymer Graphite) design. It easily rides over warps, behaves calmly in the face of record eccentricities and smoothly glides through high-amplitude grooves. With resonance conquered, musical information — and musical information alone — is accurately retrieved.

On the headshell is of a low-mass design to keep resonance under control. Oxygen-free signal leads, running inside the tone arm, are used to prevent signal loss and

enhance clarity. We recommend that you couple a high-quality, high-compliance cartridge with the PL-8, so that you'll enjoy all the full dynamics and clarity possible with this amazing tone arm system.

Accurate platter rotation is assured by the Pioneer coreless motor, coupled with a Stable Hanging Rotor and controlled by the Quartz-PLL servo system. The motor is coreless and brushless to assure smooth rotation; the Stable Hanging Rotor provides stable dynamic balance; and the Quartz-PLL servo features a quartz reference system that compensates for any minute errors in rotational speed hundreds of times per second. It's no accident, then, that the PL-8 offers enviably low wow and flutter of no more than 0.025% (WRMS).

Acoustic feedback, a common phenomenon with lesser turntables that can subtly and even grossly tarnish reproduction quality, is prevented by the Coaxial Suspension system of the PL-8. It effectively isolates the arm and motor from the cabinet through the use of shock-absorbing spring-loaded feet.

The PL-8 is a fully automatic turntable. All controls except for arm elevation are up front, positioned outside the closed dust cover. LEDs and self-illuminated buttons let you know the operating status of the turntable at all times. If the mood strikes you, REPEAT lets you play a record over and over. It's a safe bet to say that you'll never find a turntable as well engineered and as easy to use as the PL-8.



# PL-7

**PG**<sup>TM</sup>  
POLYMER GRAPHITE



\*Metal-like resin cabinet.

## Pioneer Technology Inside and Out

FROM THE BOTTOM UP AND FROM the top down, the PL-7 is replete with features only Pioneer can provide — like the PG low-mass straight tone arm, the Stable Hanging Rotor DC motor, a Quartz-PLL servo system, and much more.

Starting from the bottom, the PL-7's base is a design we call Coaxial Suspension. It's an effective safeguard against mistracking and (in the worst cases) audible howling caused by acoustic feedback. The arm and motor are isolated via spring-loaded rubber insulators from the cabinet. This Pioneer design shuts out floor- and air-borne vibrations completely. The significance of Coaxial Suspension is best shown by the remarkable signal-to-noise ratio of the PL-7 — no less than 78dB!

Moving inside the PL-7, you'll discover the elaborate platter rotation system that provides constant speed accuracy. Central to this system is Pioneer's coreless DC motor. It forgoes slots, resulting in smooth, cog-free rotation. Brushes are replaced by semiconductor Hall elements for noiseless, non-wear polarity switching. The Stable Hanging Rotor crowning the motor ends platter wobble. And finally, the Quartz-PLL servo system has eliminated the last vestiges of rotational speed aberrations so that wow and flutter of only 0.025% (WRMS) is measurable.

Taking a look at the tone arm system, you'll find it is constructed on the low mass principle from tip to base. The arm is straight and made of Pioneer's PG (Polymer Graphite).

Tough, lightweight and resistant to resonance, our PG arm displays all the desirable properties of the perfect tone arm. Reproduction is faultlessly clean with even warp-induced distortion kept to extremely low levels. The headshell, made of a low-mass resin, is offset to reduce horizontal tracking error to a bare minimum throughout record play.

All controls except arm elevation are on the slanted front edge and are light-touch sensitive. An indicator lights when the speed is quartz locked. Operation is all automatic from lead-in to arm return and shutoff.



# PL-5

**PG**<sup>TM</sup>  
POLYMER GRAPHITE



\*Metal-like resin cabinet.

## A No-Compromise Fully Automatic

WE AT PIONEER BELIEVE THAT THE PL-5 will steal the heart of many an audiophile because of its no-compromise performance and design. It represents nearly every Pioneer advancement in recent turntable technology.

Your listening pleasure will never be disturbed by wow and flutter, for the PL-5 keeps it at no more than 0.025% (WRMS) with its Stable Hanging Rotor DC Servo Motor. Cogging is absent because of its coreless design. Noise and vibration won't mix with audio signals because electronic switching is performed by Hall elements in direct-drive motor. Speed fluctuations are suppressed by the Stable Hanging Rotor that minimizes platter wobble.

The low-mass straight tone arm of the

PL-5 is constructed of a new substance called PG (Polymer Graphite). Its inherent qualities — high firmness, good vibration-damping characteristics and light weight — make it the ideal tone arm material. Our PG tone arm displays admirable high tracking ability and sensitivity, so high, in fact, that record warps and other pressing aberrations can't affect reproduction quality. Pioneer suggests that you mate it with a high-quality, high-compliance cartridge for optimum performance. A successful combination will effectively render warps and resonance utterly harmless. Reproduction quality will be beyond reproach.

The PL-5 is a real standout when it comes to battling acoustic feedback thanks to the Coaxial Suspension system. It protects

the tone arm (and the mounted cartridge) from both air-borne and structurally-transmitted feedback for pure, unmuddied musicality.

Fully automatic operation of the PL-5 is simplicity itself. All controls — except cueing — are neatly laid out on the slanted front edge, accessible even with the dust cover closed.



# PL-4

**PG**<sup>TM</sup>  
POLYMER GRAPHITE



\*Metal-like resin cabinet.

## A Turntable with Auto-Return Convenience

THE PL-4 IS AN AUTO-RETURN TURNTABLE. All its essential controls — speed, pitch control (with strobe) and cut — are grouped on the slanted front edge. Placing a record on the platter and moving the tone arm over to it is all that is necessary to enjoy record play. There's no need to physically touch the tone arm at any other time: the arm automatically returns to its rest when play is over. Even arm cueing is provided by an arm elevation device located at the base of the arm.

The arm is straight-contoured and constructed of low-mass PG (Polymer Graphite). It is rigid, resistant to resonance, and lightweight. Record warps, eccentricities and cartridge/arm resonance pose no obstacles to accurate tracking. Sensitivity is

increased by the low-mass design and distortion is measurably reduced.

The PL-4 employs the Pioneer coreless DC servo motor with Stable Hanging Rotor. Designed without cores, slots and brushes, it offers the smoothest cog-free rotation. Because of electronic switching by Hall elements, it does not generate switching noise and years of reliable performance are assured. Mated with this advanced motor is an equally precise Periphery Integration speed detection circuit. It compensates for the minutest error in rotational speed four hundred times per second. The result is impeccable short-term and long-term speed accuracy.

Both the delicate cartridge and the tone arm are protected from acoustic feedback

by the Coaxial Suspension system which mounts the motor and arm on a separate subchassis. Neither air-borne nor floor-borne vibrations are capable of affecting the tone arm; its base is isolated from the cabinet and suspended by four spring-loaded feet.

All in all, the PL-4 is a tough act for any competitive model in the same price range to follow because of its high-value features and top-flight specifications.



# PL-2

**PG**<sup>TM</sup>  
POLYMER GRAPHITE



\*Metal-like resin cabinet.

## A Belt-Drive Turntable Updated

A POORLY-ENGINEERED DIRECT-drive turntable is inferior to a well-engineered belt-drive turntable — that's the axiom we have believed in and followed over the years. A prime example is the PL-2 belt-drive turntable. For its price and performance, it beats any competitive model, belt or direct driven, hands down.

The belt-drive system of the PL-2 is an updated version that provides all the necessary torque and accurate speed control. A finely polished elastic belt is driven by a Pioneer DC motor. The motor assures smooth platter rotation, while the belt absorbs all traces of vibration while powerfully transmitting motive power from the motor to the platter.

Where the PL-2 differs from the conven-

tional belt-drive model is its Stable Hanging Rotor, a kind of cup fitted to the shaft under the platter. It gives the platter a stabilizing force that keeps the platter steady as it revolves, reducing potential platter wobble.

Giving the PL-2 a distinctive look is a straight low-mass PG tone arm. Since it is insensitive to resonance and hence to warps and eccentricities of records, it tracks even the most difficult-to-follow record grooves easily. The arm combines high tracking ability with high sensitivity to permit the use of any cartridge, whatever its compliance or operating principle.

Like all Pioneer turntables, the Coaxial Suspension system protects the arm, cartridge and records from acoustic feedback. And that's the reason why the PL-2

boasts a high signal-to-noise ratio of 68dB.

The PL-2 is an auto-return model. At the end of play, the arm automatically returns to its rest and shuts the power off. Operation couldn't be simpler: There's just one control — for speed selection — on the slanted front edge of the turntable.



# SPECIFICATIONS

	PL-L800	PL-8	PL-7
<b>MOTOR AND TURNTABLE</b>			
Drive System:	Quartz-PLL direct-drive	Quartz-PLL direct-drive	Quartz-PLL direct-drive
Motors:	Direct-induction linear motor (for tangential tracking tone arm drive, Quartz-PLL Coreless DC-Servo Stable Hanging Rotor™ Hall-motor (for platter drive)	Quartz-PLL Coreless DC-Servo Stable Hanging Rotor™ Hall-motor	Quartz-PLL Coreless DC-Servo Stable Hanging Rotor™ Hall-motor
Speeds:	33-1/3 and 45 rpm	33-1/3 and 45 rpm	33-1/3 and 45 rpm
Wow and Flutter (WRMS):	No more than 0.012%* (*measured directly from FG output), No more than 0.025%	No more than 0.012%* (*measured directly from FG output), No more than 0.025%	No more than 0.012%* (*measured directly from FG output), No more than 0.025%
Signal-to-Noise Ratio (DIN B):	More than 78dB	More than 78dB	More than 78dB
<b>STONE ARM</b>			
Type:	Direct-induction linear motor drive, Static-balanced Tangential tracking low mass Polymer Graphite™ straight pipe arm	Static-balanced low mass Polymer Graphite™ straight pipe arm	Static-balanced low mass Polymer Graphite™ straight pipe arm
Effective Arm Length:	6-3/8 inches (162mm)	8-11/16 inches (221mm)	8-11/16 inches (221mm)
Overhang:	0mm	5/8 inches (15.5mm)	5/8 inches (15.5mm)
Usable Cartridge Weight:	3g (min.) to 8g (max.)	3g (min.) to 8g (max.)	3g (min.) to 8g (max.)
<b>CARTRIDGE</b>			
Type:	Moving-Coil type (model PC-4MC)		
Frequency Response:	10 to 35,000Hz		
Output Voltage:	1.5mV		
Load Impedance:	30k—100k ohms		
Stylus:	0.3 × 0.7 mil diamond (model PN-4MC)		
Stylus Pressure:	2g ±0.3g		
<b>MISCELLANEOUS</b>			
Power Requirement:	120V 60Hz	120V 60Hz	120V 60Hz
Power Consumption:	22 watts	15 watts	12 watts
Dimensions: (without package)	16-9/16(W) × 4-3/4 (H) × 16-13/16(D) inches 420(W) × 120(H) × 427(D) mm	16-9/16(W) × 4-1/2(H) × 15-9/16(D) inches 420(W) × 114(H) × 395(D)mm	16-9/16(W) × 4-1/4(H) × 14-7/16(D) inches 420 (W) × 108(H) × 367(D)mm
Weight (without package):	18 lbs. 5 oz./8.3kg	13 lbs. 11 oz./6.2kg	13 lbs./5.9kg
<b>OTHER FEATURES</b>			
	<ul style="list-style-type: none"> <li>Fully Automatic Lead-in/Cut/Return/Quick Repeat</li> <li>Direct-readout counterweight</li> <li>Quick-Start/Stop system</li> <li>Electronic cueing device</li> <li>Free-hinged acrylic cover</li> </ul>	<ul style="list-style-type: none"> <li>Fully Automatic Lead-in/Cut/Return/Repeat</li> <li>Direct-readout counterweight</li> <li>Quick-Start/Stop system</li> <li>Anti-skating device</li> <li>Oil-damping cueing device</li> <li>Free-hinged acrylic cover</li> </ul>	<ul style="list-style-type: none"> <li>Fully Automatic Lead-in/Cut/Return/Repeat</li> <li>Direct-readout counterweight</li> <li>Quick-Start/Stop system</li> <li>Anti-skating device</li> <li>Oil-damping cueing device</li> <li>Free-hinged acrylic cover</li> </ul>

## Feature Comparison Chart for Pioneer Turntables

	PL-L800	PL-8	PL-7	PL-5	PL-4	PL-2
Drive System						
Direct-Drive	○	○	○	○	○	—
Belt-Drive	—	—	—	—	—	○
Automatic Operation						
Full	○	○	○	○	—	—
Auto-Return	—	—	—	—	○	○
Coreless DC Motor with Stable Hanging Rotor	○	○	○	○	○	—
Quartz-PLL Servo System	○	○	○	—	—	—
Periphery Integration Speed Detection	○	○	○	○	○	—
Low-mass Straight PG Tone Arm	○	○	○	○	○	○
Tangential Tracking Arm Design	○	—	—	—	—	—
Low-mass Head Shell	○	○	○	○	○	○
MC Cartridge (PC-4MC)	○	—	—	—	—	—
Coaxial Suspension	○	○	○	○	○	○



PL-1	PL-4	PL-2
Direct-drive Coreless DC-Servo Stable Hanging Rotor™ Hall-motor	Direct-drive Coreless DC-Servo Stable Hanging Rotor™ Hall-motor	Belt-drive DC-Servo motor
33-1/3 and 45 rpm No more than 0.012%* (*measured directly from FG output), No more than 0.025% More than 78dB	33-1/3 and 45 rpm No more than 0.014%* (*measured directly from FG output), No more than 0.025% More than 78dB	33-1/3 and 45 rpm  No more than 0.05% More than 68dB
Static-balanced low mass Polymer Graphite™ straight pipe arm	Static-balanced low mass Polymer Graphite™ straight pipe arm	Static-balanced low mass Polymer Graphite™ straight pipe arm
8-11/16 inches (221mm) 5/8 inches (15.5mm) 3g (min.) to 8g (max.)	8-11/16 inches (221mm) 5/8 inches (15.5mm) 3g (min.) to 8g (max.)	8-11/16 inches (221mm) 5/8 inches (15.5mm) 3g (min.) to 8g (max.)
120V 60Hz 12 watts 16-9/16(W) × 4-1/4(H) × 14-7/16 (D) inches 420(W) × 108(H) × 367(D)mm 13 lbs./5.9kg	120V 60Hz 12 watts 16-9/16(W) × 4-1/4 (H) × 14-7/16(D) inches 420(W) × 108(H) × 367(D)mm 12 lbs. 13 oz./5.8kg	120V 60Hz 3 watts 16-9/16(W) × 4-1/4(H) × 14-7/16(D) inches 420(W) × 108(H) × 367(D)mm 11 lbs. 4 oz./5.1 kg
<ul style="list-style-type: none"> <li>• Fully Automatic Lead-in/Cut/Return/Repeat</li> <li>• Direct-readout counterweight</li> <li>• Quick-Start/Stop system</li> <li>• Anti-skating device</li> <li>• Oil-damping cueing device</li> <li>• Free-hinged acrylic cover</li> </ul>	<ul style="list-style-type: none"> <li>• Auto-Return, Auto-shut-off</li> <li>• Quick-Play/Stop system</li> <li>• Direct-readout counterweight</li> <li>• Anti-skating device</li> <li>• Oil-damping cueing device</li> <li>• Free-hinged acrylic cover</li> </ul>	<ul style="list-style-type: none"> <li>• Auto-Return, Auto-shut-off</li> <li>• Quick-Play/Stop system</li> <li>• Direct-readout counterweight</li> <li>• Anti-skating device</li> <li>• Oil-damping device</li> <li>• Free-hinged acrylic cover</li> </ul>

Note: Specifications and design subject to possible modification without notice.



 **PIONEER®**

PIONEER ELECTRONIC CORPORATION  
4-1, Meguro 1-chome, Meguro-ku, TOKYO 153, JAPAN



 **PIONEER**  
TANGENTIAL TRACKING  
QUANTZ-PLL FULL-AUTOMATIC PL-L900